

# TIG 17

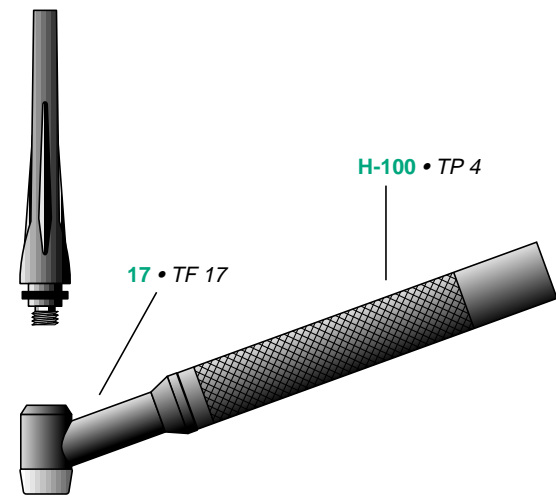

**TIG 17-12-2** (12.5) • TA 8700  
**TIG 17-25-2** (25) • TA 8715

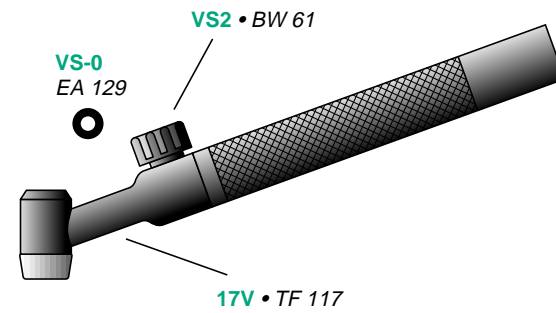

**TIG 17V-12-2** (12.5) • TA 8760  
**TIG 17V-25-2** (25) • TA 8775

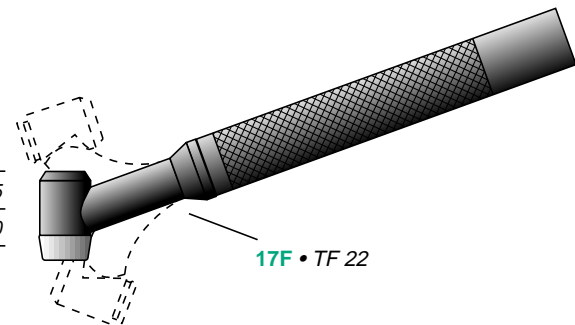

**TIG 17F-12-2** (12.5) • TA 8705  
**TIG 17F-25-2** (25) • TA 8720

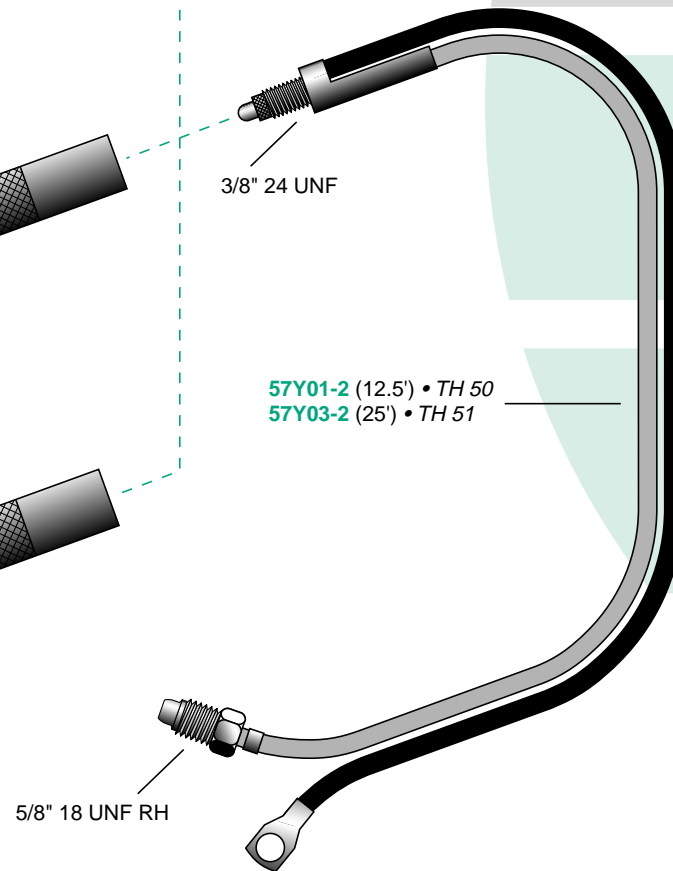

### Protective Cover

TT 111 Cable cover 3"x10'  
TT 112 Cable cover 3"x22'

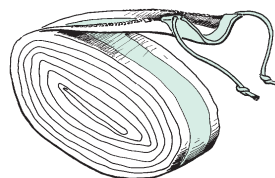

### Accessory Kits

<b>TT 103 • 1/16"</b>	<b>TT 104 • 3/32"</b>	<b>TT 105 • 1/8"</b>
1 Collet 1 Collet body 1 Nozzle 13N10 1 Tungsten electrode	1 Collet 1 Collet body 1 Nozzle 13N10 1 Tungsten electrode	1 Collet 1 Collet body 1 Nozzle 13N10 1 Tungsten electrode

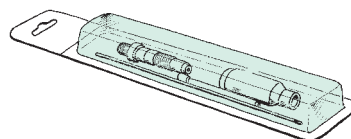

PLUG 25 • CX 20

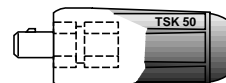

PLUG 50 • CX 22



### Capacity

150 Amp Tig - Gun  
Air-Cooled

### Electrode Range

.020-3/32" (.5-2.4 mm)



**trafimet** USA  
your welding partner

700 East Elm Avenue, Uni B  
La Grange, IL - 60525  
Ph. 708 - 5795893 • Fax 708 - 5795884  
E-mail: TrafimetUS@aol.com

We reserve the right to modify, without notice, any of our products.  
TRAFIMET spa is the registered owner of all trademarks patents and models.

Copyright © September 1997 • by TRAFIMET spa

**trafimet** USA  
your welding partner

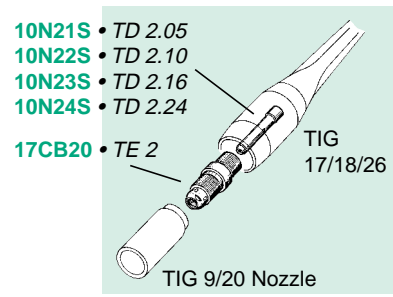
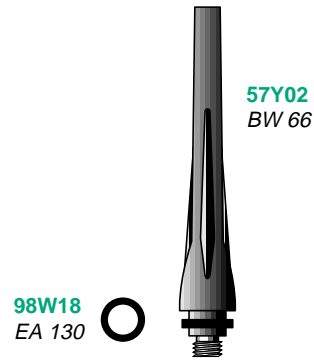

- 10N21 (.020") • TD 1.05
- 10N22 (.040") • TD 1.10
- 10N23 (1/16") • TD 1.16
- 10N24 (3/32") • TD 1.24

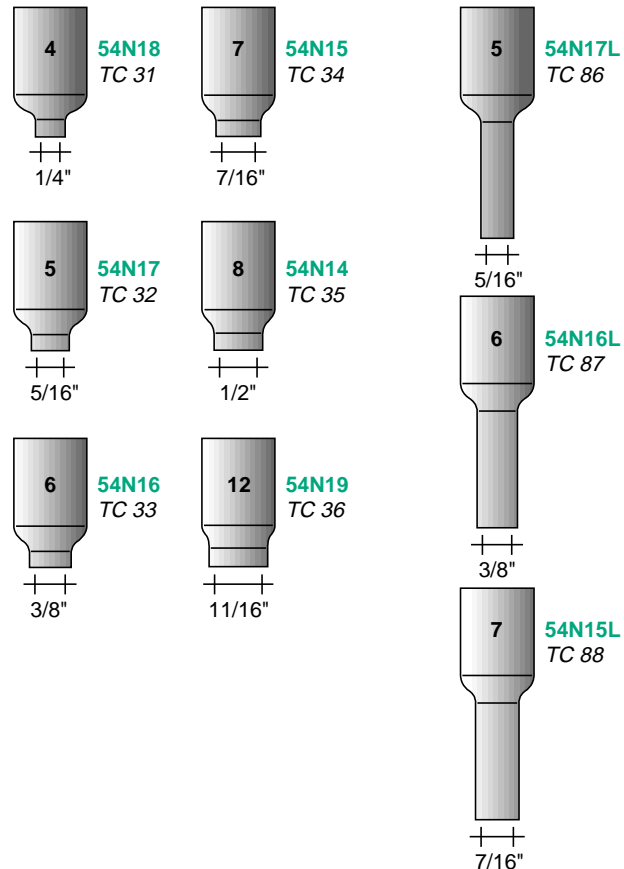
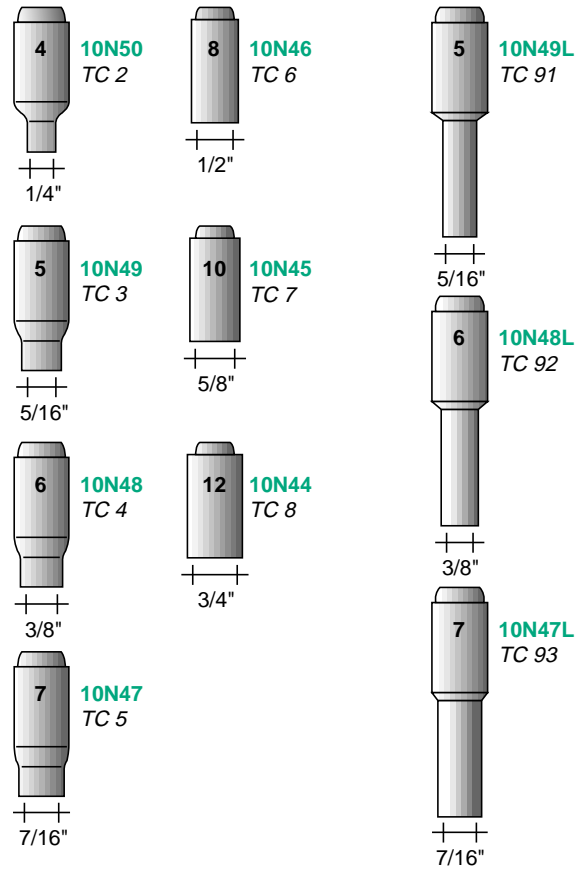
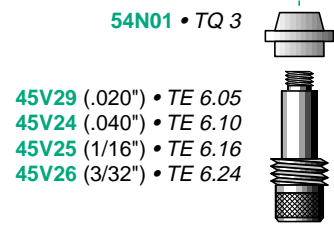
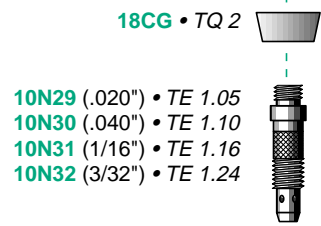

- TIG 17-12-1 (12.5) • TA 8701
- TIG 17-25-1 (25) • TA 8716
- TIG 17-12-1R (12.5) • TA 8702
- TIG 17-25-1R (25) • TA 8717

- TIG 17V-12-1 (12.5) • TA 8762
- TIG 17V-25-1 (25) • TA 8777
- TIG 17V-12-1R (12.5) • TA 8763
- TIG 17V-25-1R (25) • TA 8778

- TIG 17F-12-1 (12.5) • TA 8703
- TIG 17F-25-1 (25) • TA 8718
- TIG 17F-12-1R (12.5) • TA 8704
- TIG 17F-25-1R (25) • TA 8719

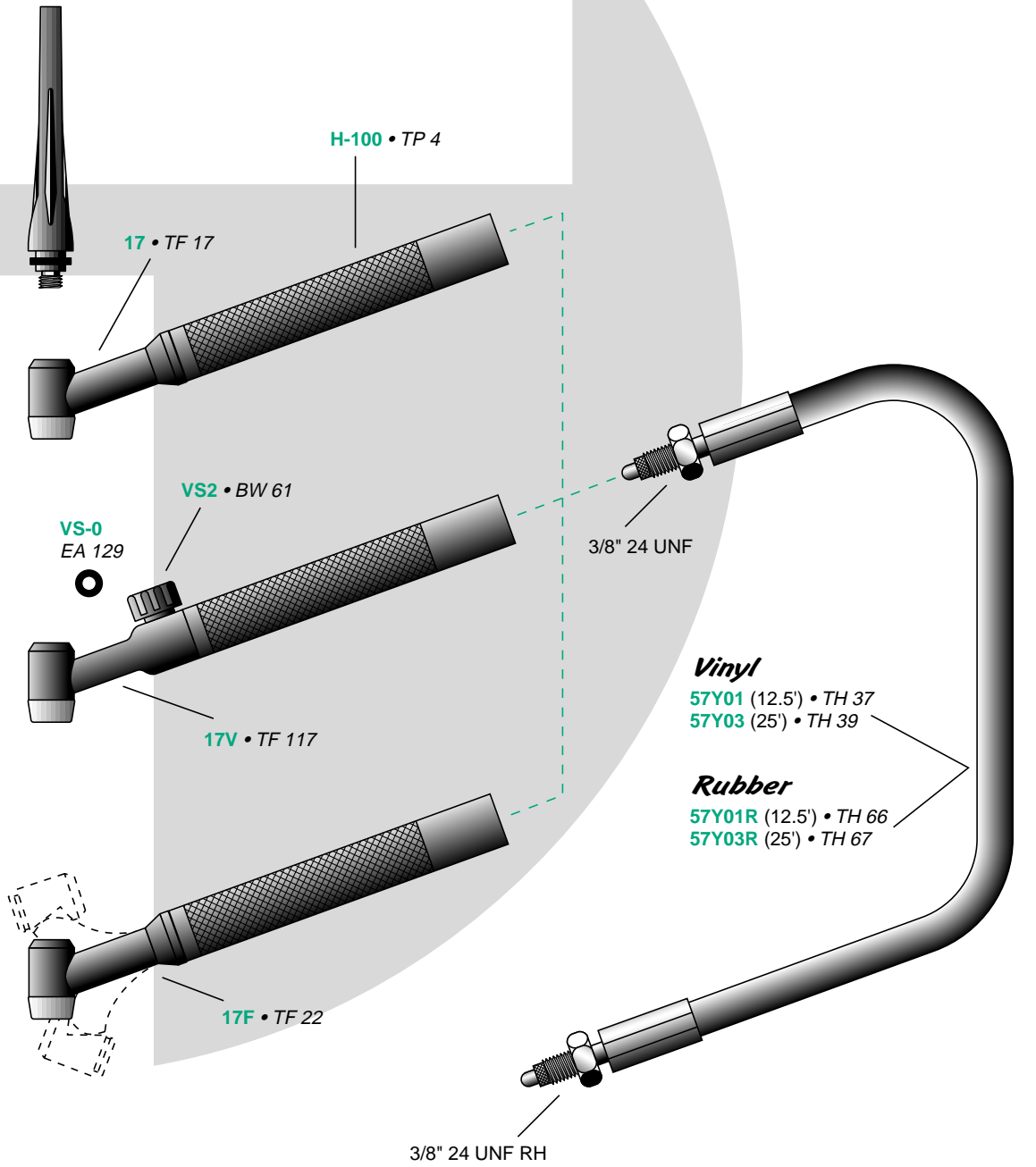

- SW1-12 • BX 352
- SW1-25 • BX 353

BS 1  
BW 71



ADAPTOR 25/50 • CX 70

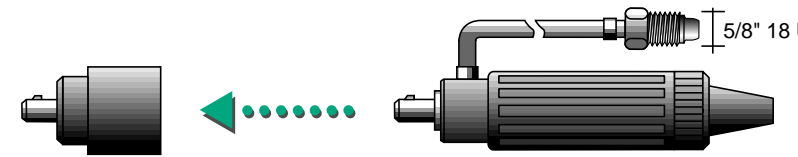

PLUG 50 T • CX 150

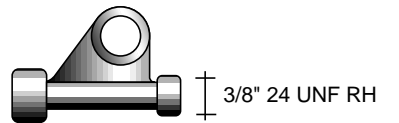

105Z57 • FE 48